

Arch Environmental Equipment, Inc.

SUPER SABER BELT CLEANER

INSTALLATION INSTRUCTIONS

THE INSTALLATION OF THE SUPER SABER BELT CLEANER IS VERY SIMPLE.
IT REQUIRES ONLY A FEW TOOLS AND LITTLE TIME.

THE TOOLS & RESOURCES REQUIRED ARE:

- | | |
|------------------|-------------------------|
| 1. STRAIGHT EDGE | 5. WELDING EQUIPMENT |
| 2. LEVEL | 6. CHALK |
| 3. TAPE MEASURE | 7. ADJUSTABLE WRENCH |
| 4. CUTTING TORCH | 8. STRING (36" or more) |

***SHUT DOWN AND LOCKOUT CONVEYOR BEFORE
PERFORMING ANY MAINTENANCE***

STEP 1

Determine the diameter of the head pulley and the thickness of the conveyor belt. Example: head pulley diameter = 36" (914.4mm), belt thickness = 1 3/4" (44.45mm). Take one half of the head pulley measurement (in this case 18" (457.2mm)) and add the belt thickness. This will give an effective radius of 19 3/4" (501.65mm).

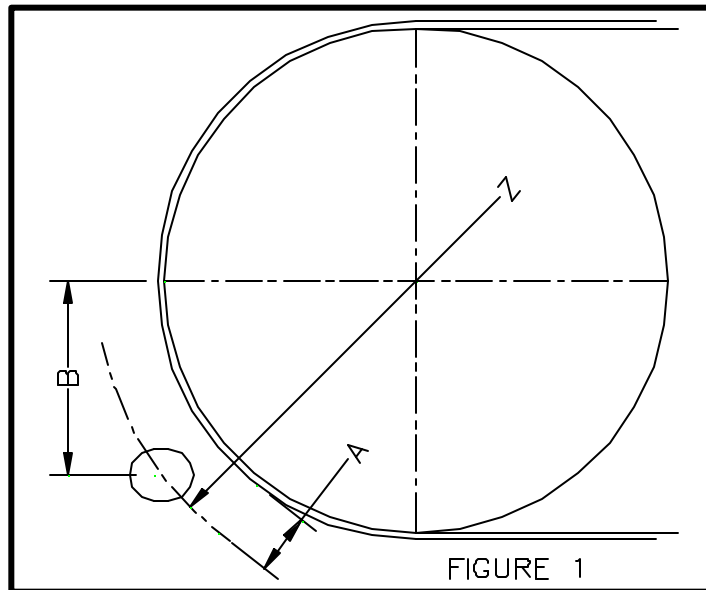

STEP 2

To this number add dimension "A" (either 4 1/4" (107.95mm) or 4 3/4" (120.65mm)). To determine dimension "A" (spacing from the face of the belt), you must first determine the head pulley diameter. If the pulley diameter is 26" or smaller, then an "A" dimension of 4 3/4" (120.65mm) should be used. If the head pulley diameter is larger than 26", use an "A" dimension of 4 1/4" (107.95mm). This will give you the "Z"

dimension. See fig. 1. To assist in achieving this spacing, urethane installation rings have been provided with the cleaner. Use them as directed in step 7.

STEP 3

Using the "Z" dimension as described in step 2, use the string and chalk to draw an arc (with radius of "Z") to define the area for cutting the mounting holes on the chute wall.

STEP 4

From the centerline of the head pulley measure down 13 ¾" (349.25mm) (See Figure 1. Dimension "B"). This is the highest point that the cleaner should be mounted. It can be mounted anywhere along the radius that was marked off in step 3. The limiting factor is the restriction of a dribble chute or lack of a dribble chute at the point where the belt leaves the head pulley on the return side. **Note: DO NOT install the cleaner within the trajectory of the material.**

STEP 5

After you have located the correct position to mount the cleaner, mark two oval shaped holes approximately 3 ½" (88.9mm) x 4 ½" (114.3mm) in size. These should now be torched or cut out. **NOTE: DO NOT USE EXISTING HOLES FROM ANOTHER BRAND OF CLEANER.**

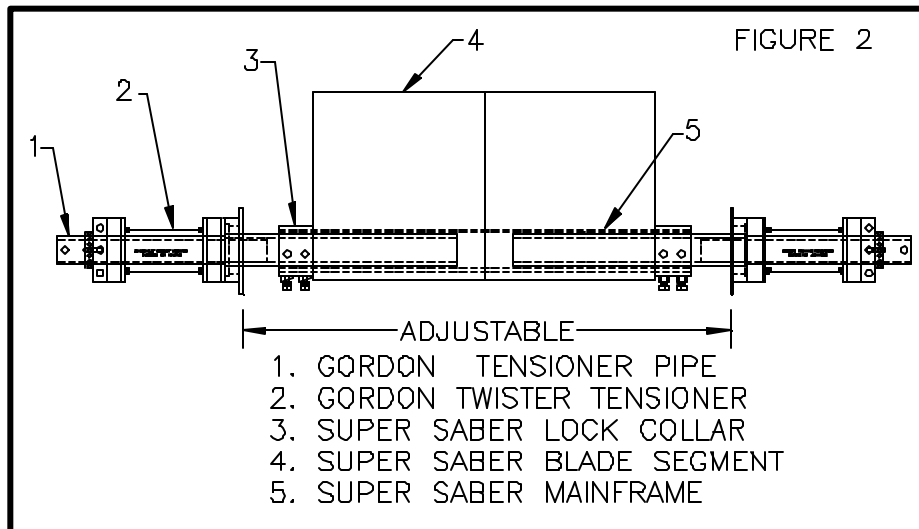

STEP 6

Disassemble the cleaner. This is done by removing the pin on the tensioner (Item 2) at the end of the tensioner hub. Remove the tensioner (Item 2) from the tensioner pipe (Item 1). You will find the tensioner wrench inside the tensioner pipe. Loosen the set screws on the lock collars (Item 3). **Caution! Loosen them only enough to allow both tensioner pipes (Item 1, Qty. 2) to be removed from the cleaner mainframe (Item 5).**

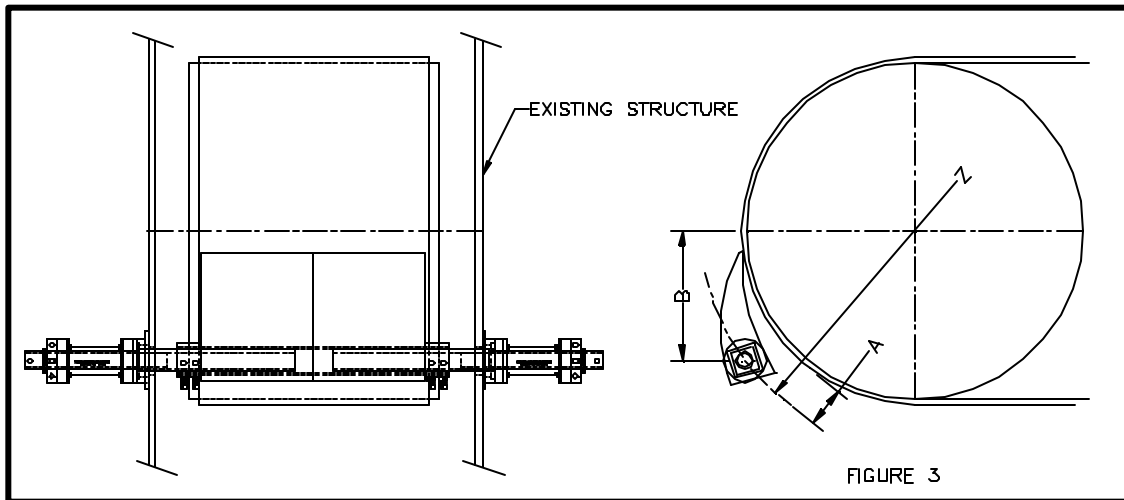

FIGURE 3

STEP 7

Put the frame and blade assembly (Items 3, 4, & 5) inside the chute, and slide the tensioner pipes (Item 1) through the holes previously cut in the structure. Then slide the tensioners (Item 2) onto the tensioner pipes. The bushing inside the tensioner hub should fit over about 1" of the square section of the pipe. Next, level the cleaner in relation to the head pulley. Verify the "Z" dimension by slipping the urethane installation rings onto the pipes. *If the head pulley is larger than 26", remove the outer ring.* Once the "Z" dimension has been verified, tack weld the tensioners into place. Set the cleaner blade against the belt and insert both tensioner pins into both outer hubs on the tensioners. Ensure that the square section of the tensioner pipe is located within the welding hub of both tensioners. Tighten the set screws on the mainframe and complete welding on the tensioners (4 - 2" (50.8 mm) welds on each tensioner is enough). Pull the pins again to check if the cleaner rotates freely in the hubs. If it does not, realign the tensioners until the cleaner rotates freely.

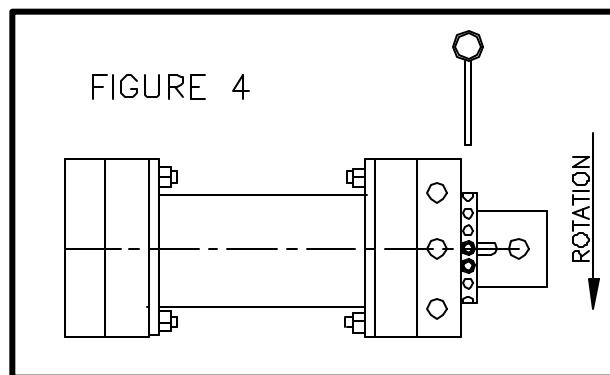

FIGURE 4

STEP 8

Finally, starting with one side pull the tensioner pin and rotate the tensioner away from the head pulley, until the next hole shows (Figure 4) in the tensioner hub. Reinstall the pin. Repeat this process for the other tensioner.

That's it!

CONVEYOR
EFFICIENCY
SPECIALISTS



P.O. Box 1760 5929 Benton Road Paducah, KY 42002-1760
(800) 553-4567 / (270) 898-6821 Fax: (800)230-9462 / (270)898-8061
<http://www.aeec.com>

Gordon Belt Cleaning Systems • Tri-Return Training Idler • Wyatt Alignment Disks • Simplicity Access Doors • Gordon "At-Last-A-Seal" Skirt Rubber Flexiskirt Sealing System • Gordon Dust Seal • Simplicity Slider System • Dust Shark Dust Suppression System • Simplicity Chute Liner • Fogger System
Simplicity Impact System • Conveyor Controls & Belt Protection Equipment • ArchWeigh Belt Scales • Metasearch Metal Detector