

# CTS 700 OSU<sup>®</sup> BELT SPEED MONITOR

- ✓ Simple Installation
- ✓ Low Maintenance
- ✓ Fast Delivery
- ✓ Corrosion Resistant

CEMA Scale  
Duty Idler

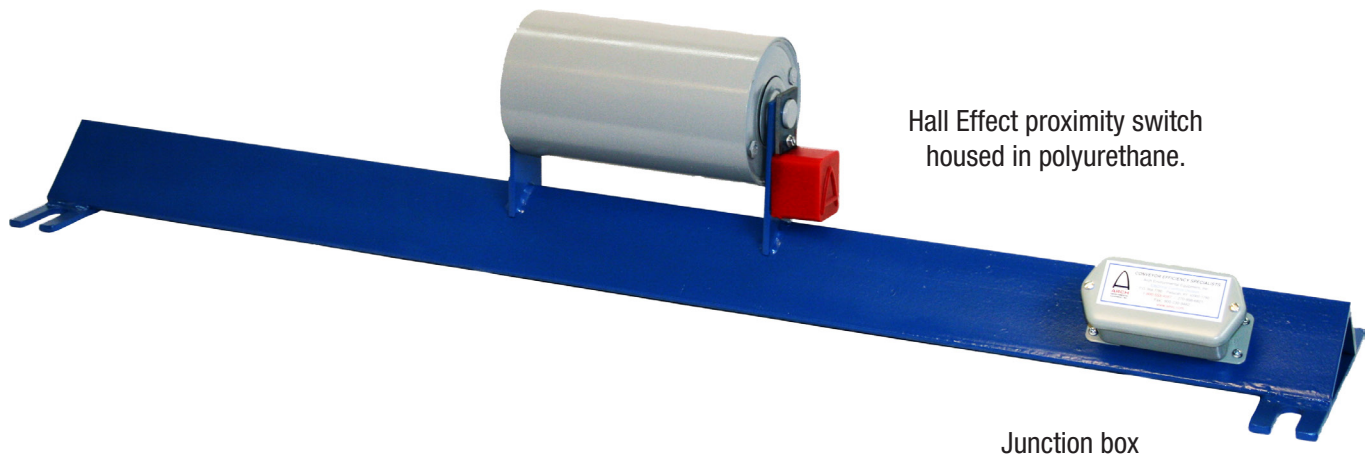

Hall Effect proximity switch  
housed in polyurethane.

Junction box

	OFF-SPEED	ZERO-SPEED
Indicates non-moving conveyor		✓
Indicates broken or slipping belts	✓	
Protects belt from under or over speed damage	✓	
Stops conveyor if drive motor speed falls below pre-determined value	✓	
Bolts to standard, pre-existing bolt holes	✓	✓
Dual speed sensor pickups	✓	✓
Immediate feedback via PLC/ variable speed drive	✓	✓
Suitable for bidirectional belts	✓	✓
2x16 easily read screen	✓	
Simple installation and setup	✓	✓



## WHO IS ARCH ENVIRONMENTAL?

Manufacturer and worldwide distributor of preferred bulk conveyor components since 1975.



800.553.4567 [www.archenv.com](http://www.archenv.com)

## MECHANICAL DIVISION

Belt Cleaners • Belt Alignment • Sealing Systems  
Dust Control Systems • Impact/Slider Systems

## ELECTRICAL DIVISION

Belt Scales • Metal Detectors • Pull Cord Switches  
Belt Protection Devices • Conveyor Control Systems

# CTS 700 OSU<sup>®</sup> BELT SPEED MONITOR

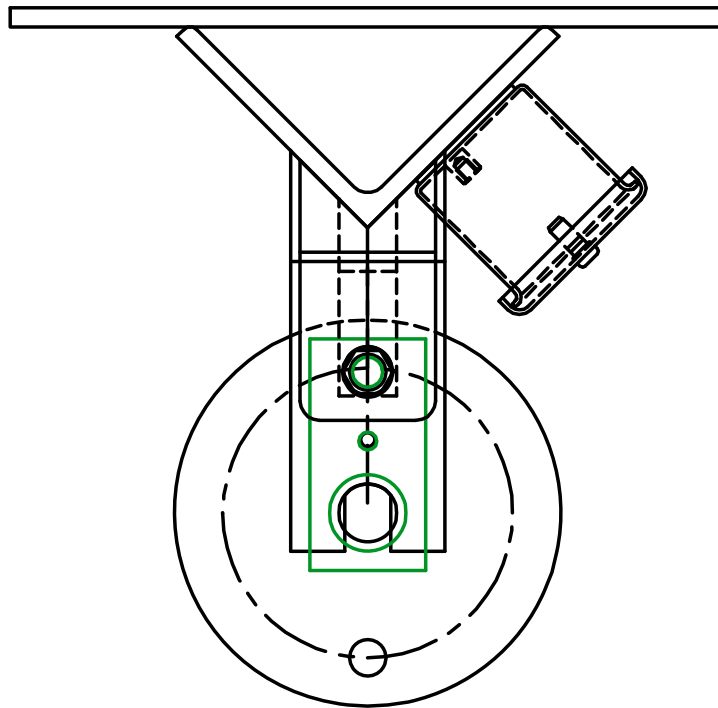
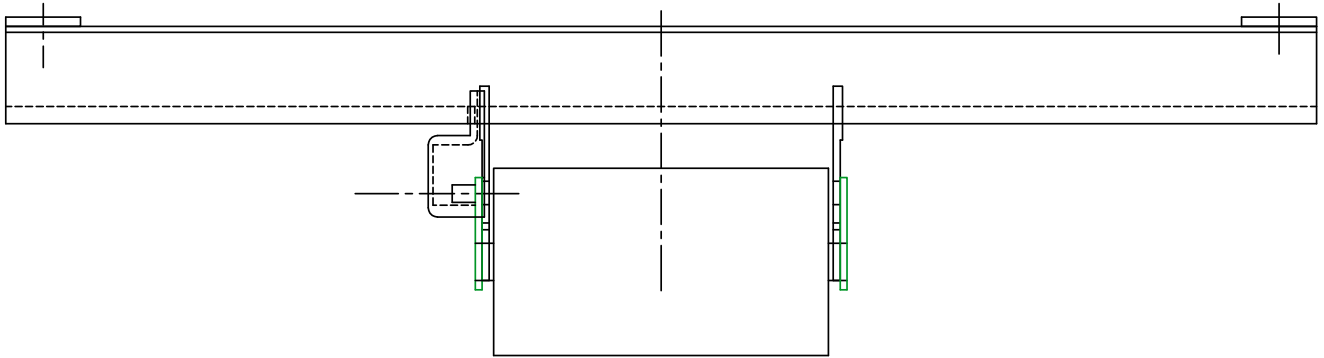

Covered under one or more of the following patents:  
4,202,437;4,231,471;4,436,446;4,489,823;4,533,036;4,779,716;4,877,125;  
4,989,727;5,149,305;5,222,588;5,222,589;5,219,063;5,350,053;5,725,083  
other patents pending



**Note:** If available, prices vary with options.