

CAM-A-LOT® CLAMP SYSTEM

- ✓ Simple Installation
- ✓ Low Maintenance
- ✓ Super Heavy-Duty
- ✓ Fast Delivery

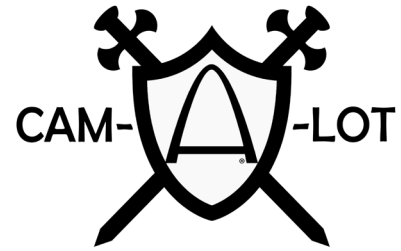

360° rotating heads allow for application specific installation and operation.

Spring-loaded release allows for easy change of skirtboard rubber.



Machined aluminum clamp heads are available in two options; quick pull handle or universal-tool.



- Optimal performance when paired with Arch Talon Seal
- Simple operation with common tools
- Works with most skirting material and profiles
- Self adjusting up to 3/4" skirting thickness
- Cam operation is multi-directional to avoid obstructions
- Available in 5ft continuous sections
- Corrosion resistant clamping cam
- Safety pin to resist accidental disengagement
- Weld on mounting



WHO IS ARCH ENVIRONMENTAL?

Manufacturer and worldwide distributor of preferred bulk conveyor components since 1975.



800.553.4567 www.archenv.com

MECHANICAL DIVISION

Belt Cleaners • Belt Alignment • Sealing Systems
Dust Control Systems • Impact/Slider Systems

ELECTRICAL DIVISION

Belt Scales • Metal Detectors • Pull Cord Switches
Belt Protection Devices • Conveyor Control Systems

CAM-A-LOT® CLAMP SYSTEM

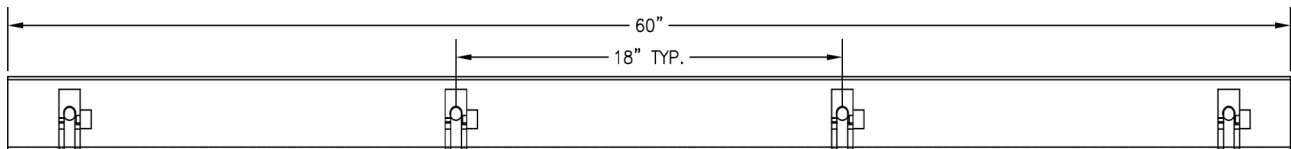
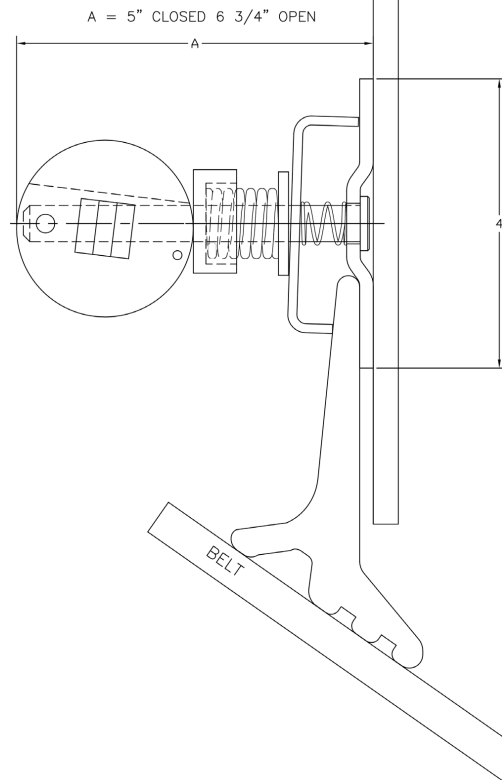
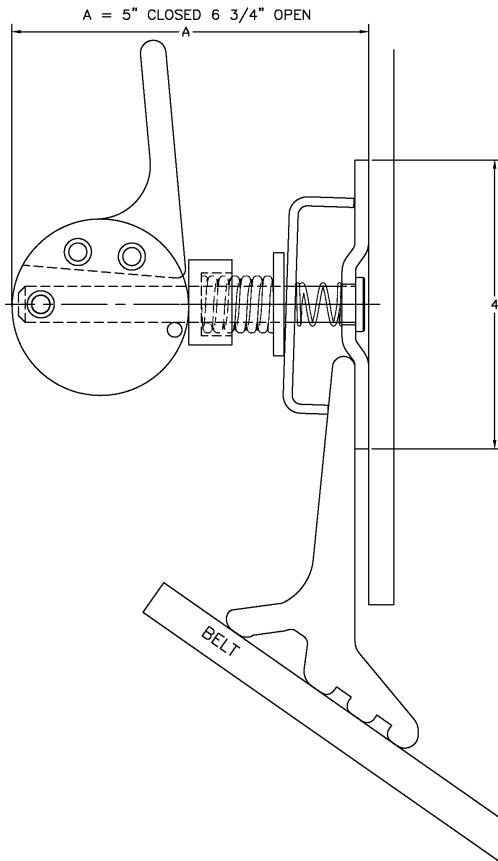

Covered under one or more of the following patents:
4,202,437;4,231,471;4,436,446;4,489,823;4,533,036;4,779,716;4,877,125;
4,989,727;5,149,305;5,222,588;5,222,589;5,219,063;5,350,053;5,725,083
other patents pending



Note: If available, prices vary with options.