

TALON® SKIRT SEAL

- ✓ Simple to Install
- ✓ See for Yourself
- ✓ Low Maintenance
- ✓ Corrosion Resistant
- ✓ Fast Delivery

7.5" skirting height attaches to existing skirt clamp without any modification.

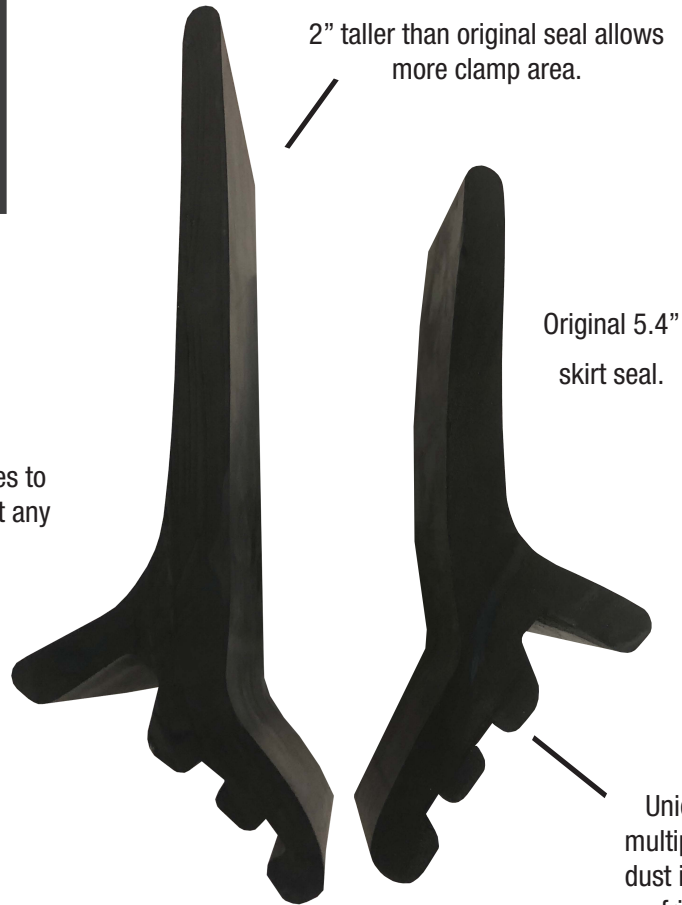

- Available in continuous lengths up to 200'.
- Wear-resistant EPDM rubber makes the Talon Dust Seal virtually indestructable.
- Talon seal made to withstand temperatures of up to 250 degrees.
- Ideal for Simplicity Impact & Slider Systems.
- Standard - MCS3
- Tall - MCS3-T



WHO IS ARCH ENVIRONMENTAL?

Manufacturer and worldwide distributor of preferred bulk conveyor components since 1975.



800.553.4567 www.archenv.com

MECHANICAL DIVISION

Belt Cleaners • Belt Alignment • Sealing Systems
Dust Control Systems • Impact/Slider Systems

ELECTRICAL DIVISION

Belt Scales • Metal Detectors • Pull Cord Switches
Belt Protection Devices • Conveyor Control Systems

TALON[®] SKIRT SEAL

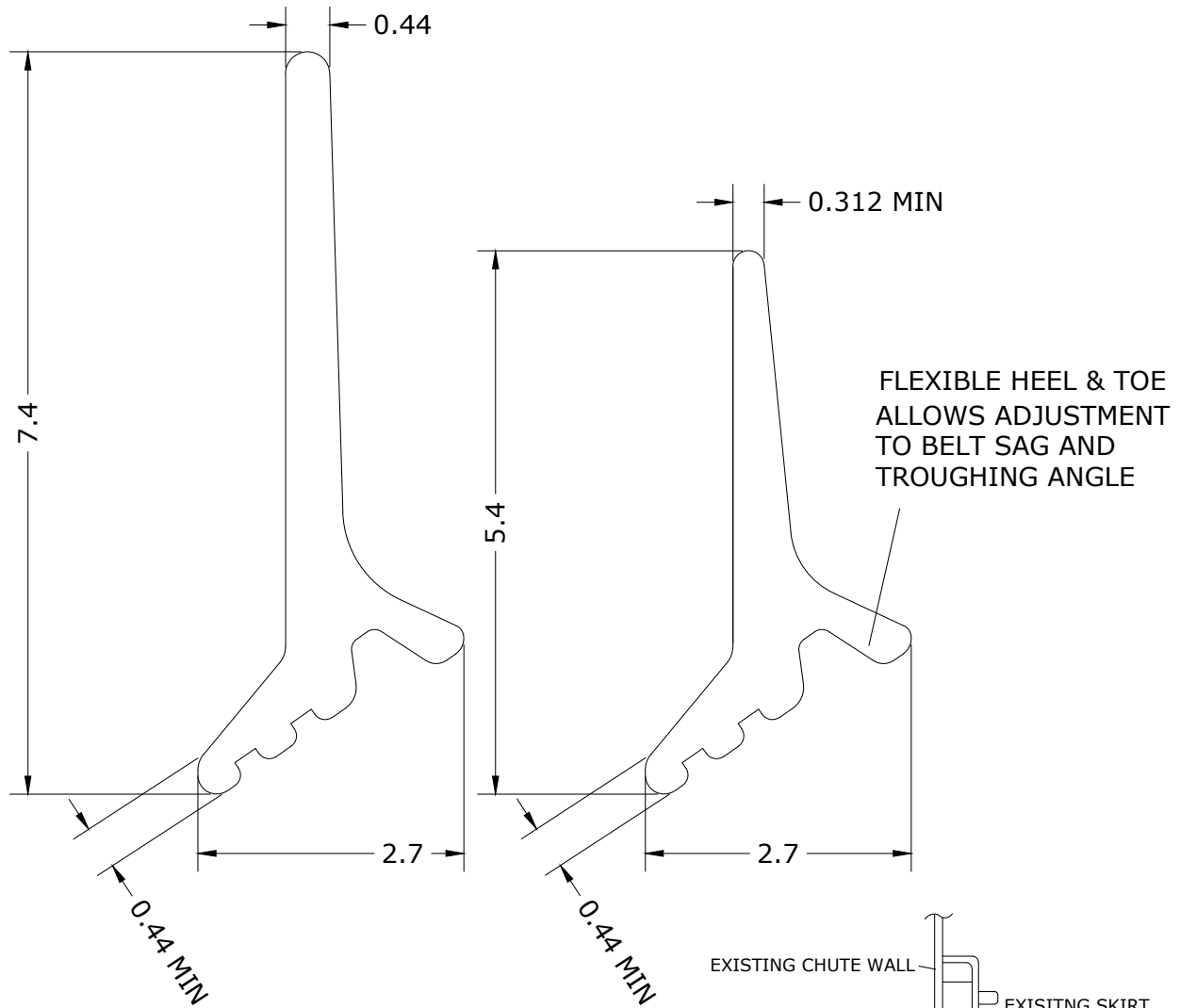

MATERIAL: BLACK EPDM RUBBER

HARDNESS: 65-75 SHORE A

TEMP. RANGE: -40C to +107C (225F) CONTINUOUS
+121C(+250F) SHORT TERM

EXCELLENT RESISTANCE TO OZONE, UV, AND WEATHER

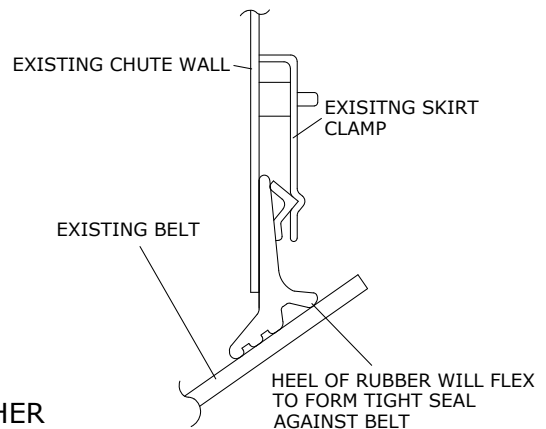

Covered under one or more of the following patents:
4,202,437;4,231,471;4,436,446;4,489,823;4,533,036;4,779,716;4,877,125;
4,989,727;5,149,305;5,222,588;5,222,589;5,219,063;5,350,053;5,725,083
other patents pending



Note: If available, prices vary with options.