

# SIMPLICITY® IMPACT SYSTEM WORKSHEET

THIS WORKSHEET IS REQUIRED FOR QUOTATIONS AND IS NEEDED BEFORE ORDERS CAN BE PROCESSED.  
PLEASE FILL OUT A PHOTOCOPY AND FAX TO ARCH ENVIRONMENTAL EQUIPMENT, INC AT (1.800.230.9462)

## COMPANY INFO

COMPANY: \_\_\_\_\_ DATE: \_\_\_\_\_  
 ADDRESS: \_\_\_\_\_  
 CITY: \_\_\_\_\_ STATE: \_\_\_\_\_ ZIP: \_\_\_\_\_  
 PHONE: \_\_\_\_\_ FAX: \_\_\_\_\_  
 CONTACT: \_\_\_\_\_ PROJECT: \_\_\_\_\_

## CONVEYOR INFO

MATERIAL SIZE: \_\_\_\_\_ BELT SPEED: \_\_\_\_\_  
 MATERIAL CONVEYED: \_\_\_\_\_ LENGTH OF IMPACT AREA: \_\_\_\_\_  
 DROP DISTANCE: \_\_\_\_\_ CONVEYOR LENGTH: \_\_\_\_\_  
 RATE MIN. (TPH): \_\_\_\_\_ RATE MAX (TPH): \_\_\_\_\_

IDLER MANUFACTURER: \_\_\_\_\_  
 MODEL NUMBER: \_\_\_\_\_  
 BELT WIDTH: \_\_\_\_\_

**THIS SECTION IS ONLY REQUIRED IF IDLER MANUFACTURER,  
MODEL NUMBER, AND BELT WIDTH ARE NOT PROVIDED ABOVE**

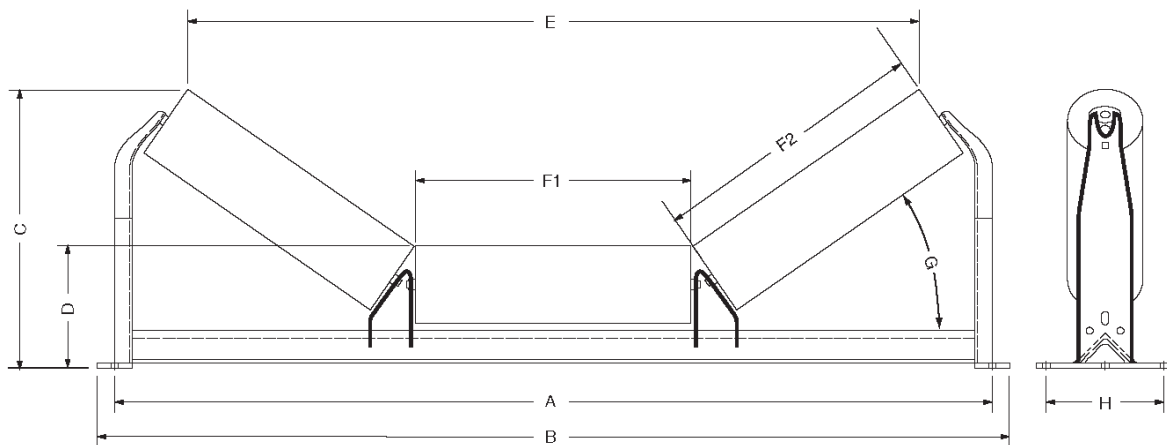

A - BOLT CENTERS: \_\_\_\_\_ B - OUTSIDE FRAMEWORK: \_\_\_\_\_  
 C - HEIGHT: \_\_\_\_\_ D - HEIGHT: \_\_\_\_\_  
 E - WIDTH: \_\_\_\_\_ F1 - LENGTH: \_\_\_\_\_  
 F2 - LENGTH: \_\_\_\_\_ G - TROUGHING DEGREE: \_\_\_\_\_  
 H - BOLT CENTERS: \_\_\_\_\_

