

Arch Environmental Equipment, Inc. ARCH TWISTER TORSION MOUNT (SECONDARY CLEANER)

Revised: August 2018, October 2018

INSTALLATION INSTRUCTIONS

THE TOOLS & RESOURCES RECOMMENDED ARE:

- | | |
|------------------|----------------------------|
| 1. TAPE MEASURE | 5. ADJUSTABLE WRENCH |
| 2. SQUARE | 6. WELDING EQUIPMENT |
| 3. CUTTING TORCH | 7. CHALK |
| 4. LEVEL | 8. 4 – 5/8" MOUNTING BOLTS |

SHUT DOWN AND LOCKOUT CONVEYOR BEFORE PERFORMING INSTALLATION OR MAINTENANCE

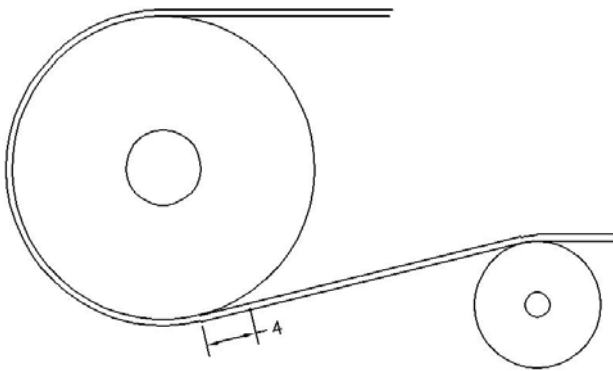

Fig 1

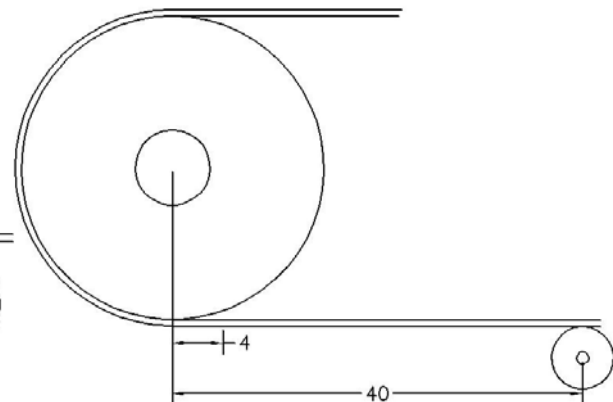

Fig 2

Step 1

The cleaner should be located in a manner that allows the blade position to be as follows:

- 1) Inclined - The recommended blade position is 4" minimum from the nip point (tangent point) where the belt leaves the head pulley in the cases where snub pulleys are installed. (Figure 1)
Vertical - The recommended blade position is 4" minimum from the vertical centerline of the head drum. (Figure 2)
- 2) For Installations where there is no snub drum, the first return roller should be installed approximately 40" from the center of the head drum (Figure 2). This will ensure that the belt is sufficiently supported. It is critical that the belt must be flat in this area. If needed install a hold down roller (not included).

Inspect area of installation. Ensure there are no cross braces, flanges, gussets, or other structure that will interfere with the belt cleaner installation or performance. If needed fabricate mounting brackets (Figure 1 – arrow) for the threaded spindles with holes to accept 5/8" bolts.

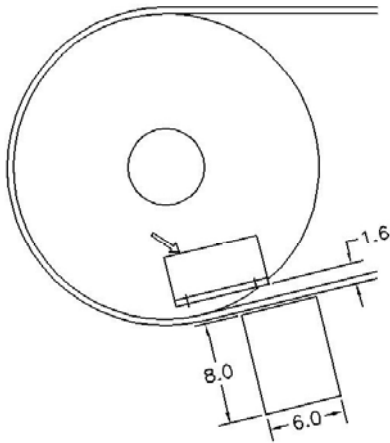

Fig 3

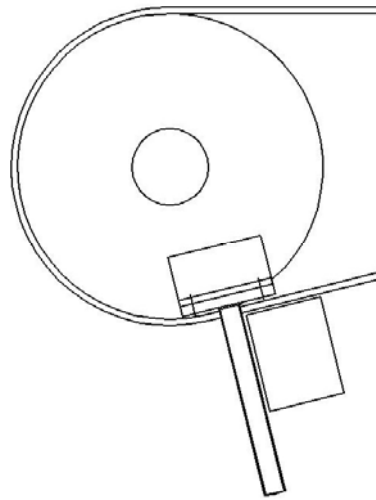

Fig 4

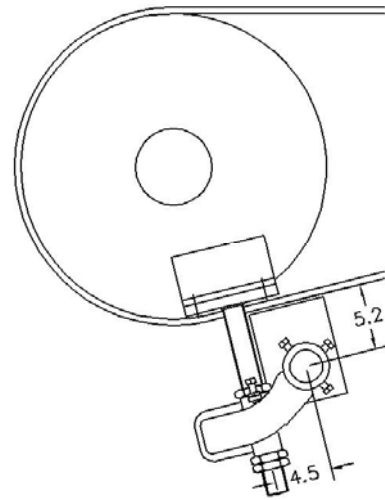

Fig 5

Step 2

Layout and Torch the cutouts for both sides of chute. Maximum size required is 6"x8", however, a smaller or larger cutout can be used (Figure 3). At this time, install brackets on both sides of chute. Ensure these brackets are parallel to the conveyor belt line. Brackets can be installed to allow the spindle to hang down (mounting bolts on top, as shown in Figure 4), or stand up (mounting foot on bottom). Either way, the brackets must be parallel to the belt.

Step 3

Attach one spindle to one of the fabricated brackets (supplied by installer – if required) on one side of the conveyor only, using 5/8" bolts. (Figure 4)

Attach one Twister Torsion Mount to the spindle using the spindle nuts to make an assembly. (Figure 5)

Note: At this stage the position of the Twister Torsion Mount on the spindle should be:

- If the spindle is to be installed in a "hanging position" approximately 1-1/4" of thread showing from the end of the spindle.
- If the spindle is to be installed in a "standing position" approximately 1-1/4" of thread showing from the foot of the spindle.
- You can also check location of the torsion arm hub in relation to the belt surface. This hub should be to tail side of the spindle as shown.

Using the second spindle and Twister Torsion Mount, assemble these parts similar to the one already in place on the structure. Locate this assembly on the opposite side of the conveyor for use in Step 4.

Step 4

Insert the Mainframe into the Twister Torsion Mount/Spindle assembly bolted to the conveyor structure. Slide the second Twister Torsion Mount/Spindle assembly onto the end of the Mainframe and lift the Scraper Unit (which now includes the second Torsion Mount/Spindle assembly) and bolt to the conveyor structure with two 5/8" bolts (not included). *Note: Once this step is completed the Mainframe with Blade will be in a hanging position.* (Figure 6)

Step 5

To preload the Twister Torsion mount, adjust the Stop Screw (arrow in Figure 6) until it touches the Torsion Arm. Continue to adjust the Stop Screw for another $3/8"$. Lock in place with the jam nut included. *Note: The Torsion Mount is now preloaded.*

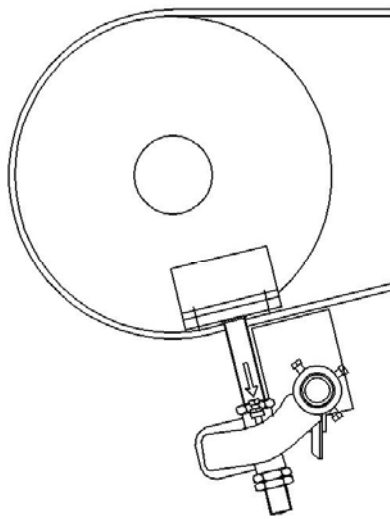

Fig 6

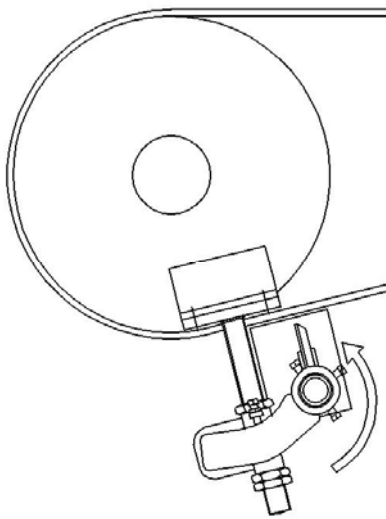

Fig 7

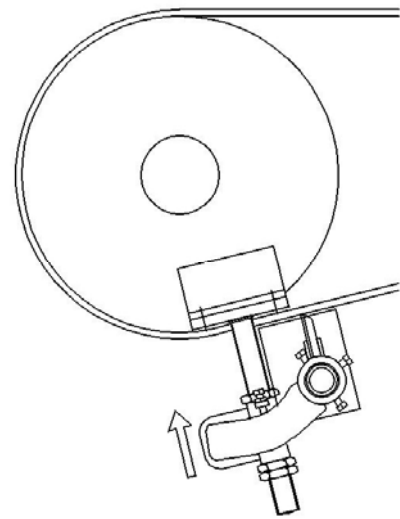

Fig 8

Step 6

Rotate the Mainframe approximately 180° so that the blade is in a perpendicular position to the belt. *Note: If you have followed the instructions correctly, the tip of the blades will be just below the belt surface.* (Figure 7)

Center the blade to the belt width. Now lightly tighten the three set screws in the torsion arm hub on each of the Twister Torsion Mounts, but only enough to ensure that the Mainframe and blade do not tip over. (Figure 7)

Step 7

Raise the Mainframe/Blade assembly until the blades touch the belt. This is done by adjusting the top and bottom nuts on the spindle. (Figure 8)

Ensure the Mainframe/Blade assembly is square to the belt and ensure the blade is perpendicular to the belt surface. If this is correct, tighten the adjustment nuts on the spindle then tighten the set screws on the torsion arm hub.

With the blade still touching the belt, loosen the jam nut on the stop screw mentioned in Step 5. Now loosen the stop screw until the ends of the threads are even with the bottom of the stop screw tab. Now retighten the jam nut on the stop screw.

Pre Start Checklist:

- Spindles are installed at 90° to the belt surface.
- Blade is perpendicular to the belt (slight negative angle is acceptable).

Start-up of the Belt

- 1) Unlock the conveyor.
- 2) Perform a test run without material, ensure there is no chatter or loose bolts.
- 3) Perform a test run with material on the belt.
 - a. Check the belt tracking.
 - b. Installation is complete.

Note: If cleaning efficiency is not being achieved adjust spindle nuts to raise the shaft assembly until correct cleaning efficiency is achieved.

If you should have any questions or comments, please contact Arch Environmental Equipment at (800) 553-4567 or fax us at (800) 230-9462.

Thank you for using Arch Environmental Equipment products!



P.O. Box 1760 5929 Benton Road Paducah, KY 42002-1760
1-800-553-4567 / 270-898-6821 Fax: 1-800-230-9462 / 270-898-8061
<http://www.aeec.com>

Gordon Belt Cleaning Systems • Tri-Return Training Idler • Wyatt Alignment Disks • Simplicity Access Doors • Gordon "At-Last-A-Seal" Skirt Rubber
Flexiskirt Sealing System • Gordon Dust Seal • Simplicity Slider System • Dust Shark Dust Suppression System • Simplicity Chute Liner • Fogger System
Simplicity Impact System • Conveyor Controls & Belt Protection Equipment • ArchWeigh Belt Scales • Metasearch Metal Detector