

# RBS SECONDARY<sup>®</sup> BELT CLEANER

- ✓ Simple Installation
- ✓ Low Maintenance
- ✓ Metal Blade
- ✓ Fast Delivery
- ✓ Worksheet Required



## MOUNTING OPTIONS

INDICATES "STANDARD" CONFIGURATION

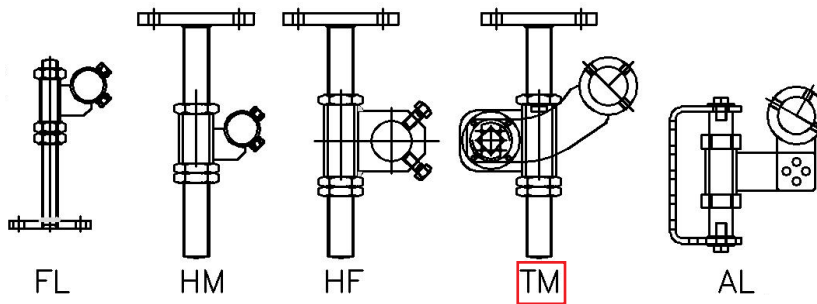

- Ultra-stable double-arm design reduces chattermarks and belt damage
- Reinforced carrier assembly withstands buckling, bending, and misalignment
- Self-adjusting blade holders compensate for blade wear.
- Cantilever design provides consistent blade-to-belt pressure.
- Single-unit compact design requires minimal space for installation (13.8"x7.1").
- Range of metal scrapers available to suit any application.
- Torsion holder assembly allows mechanical splices to pass without harm to the blade.
- Increases belt and idler life, eliminates sticky carryback.
- Reduces operation costs by extending the life of vital conveyor components.



### WHO IS ARCH ENVIRONMENTAL?

Manufacturer and worldwide distributor of preferred bulk conveyor components since 1975.



800.553.4567 [www.archenv.com](http://www.archenv.com)

### MECHANICAL DIVISION

Belt Cleaners • Belt Alignment • Sealing Systems  
Dust Control Systems • Impact/Slider Systems

### ELECTRICAL DIVISION

Belt Scales • Metal Detectors • Pull Cord Switches  
Belt Protection Devices • Conveyor Control Systems

# RBS SECONDARY<sup>®</sup> BELT CLEANER

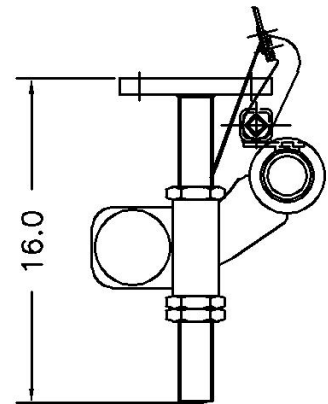
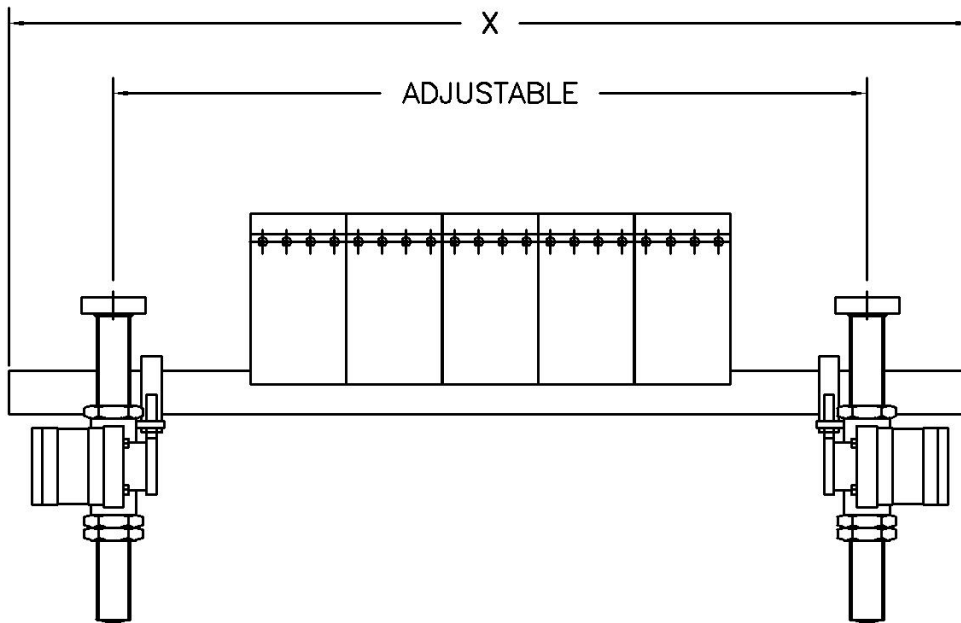
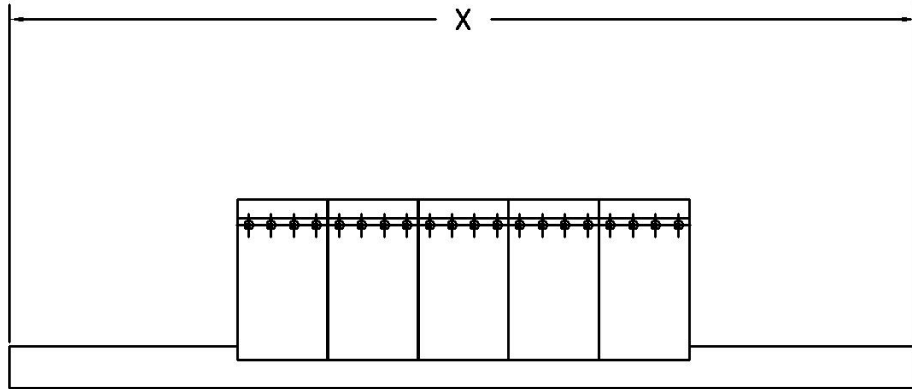

Covered under one or more of the following patents:  
4,202,437;4,231,471;4,436,446;4,489,823;4,533,036;4,779,716;4,877,125;  
4,989,727;5,149,305;5,222,588;5,222,589;5,219,063;5,350,053;5,725,083  
other patents pending



**Note:** If available, prices vary with options.