

ARCHWEIGH SC[®] BELT SCALE

- ✓ Simple Installation
- ✓ Low Maintenance
- ✓ Corrosion Resistant
- ✓ Fast Delivery
- ✓ Worksheet Required

Patented ArchWeigh dual load cells assure accuracies of +/- 1-2% by automatically zeroing out the effects of the idlers movement.

Speed unit precisely measures belt speed. Internal housing means once the scale is installed, so is the speed unit.

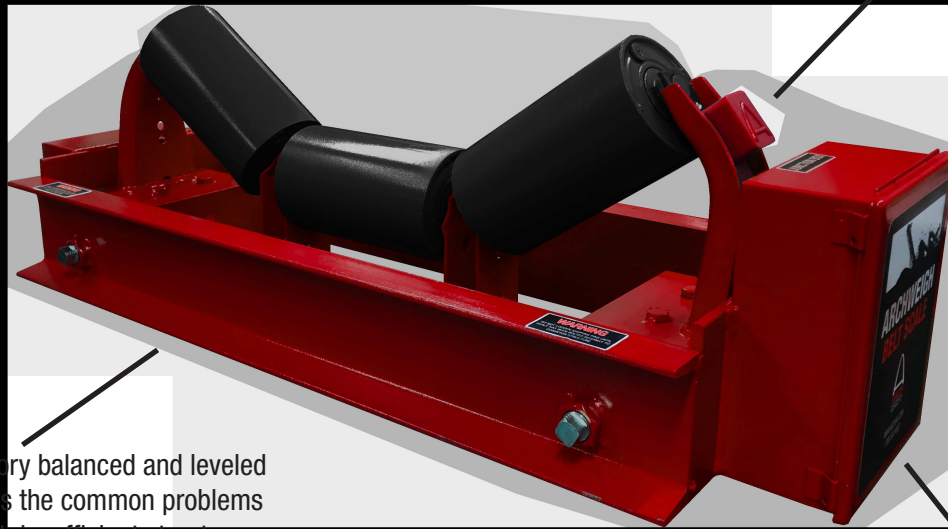

Reinforced, factory balanced and leveled frame eliminates the common problems associated with insufficient structure.

Oversized junction box for field connections.



- ArchWeigh HP Belt Scales provide long-term repeatability without recalibration.
- Accurately measures only material on the belt and eliminates the force of the moving belt.
- A complete scale carriage, not a 'do-it-yourself' kit.
- Unique dual load cell design allows for a positive/negative response to account for normal conveyor variance.
- Unitized bridge construction and internal speed sensor allow for one time 'Bolt-In-Place' installation.



WHO IS ARCH ENVIRONMENTAL?

Manufacturer and worldwide distributor of preferred bulk conveyor components since 1975.



800.553.4567 www.archenv.com

MECHANICAL DIVISION

Belt Cleaners • Belt Alignment • Sealing Systems
Dust Control Systems • Impact/Slider Systems

ELECTRICAL DIVISION

Belt Scales • Metal Detectors • Pull Cord Switches
Belt Protection Devices • Conveyor Control Systems

ARCHWEIGH SC[®] BELT SCALE

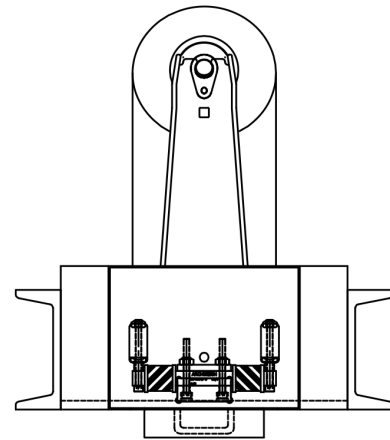
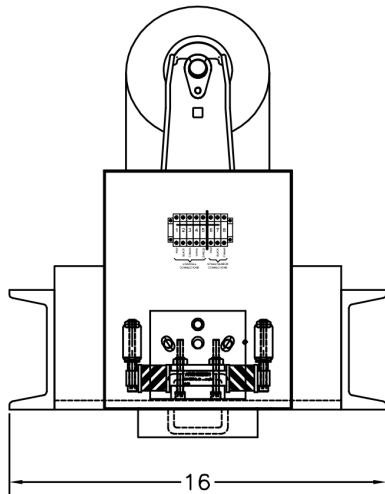
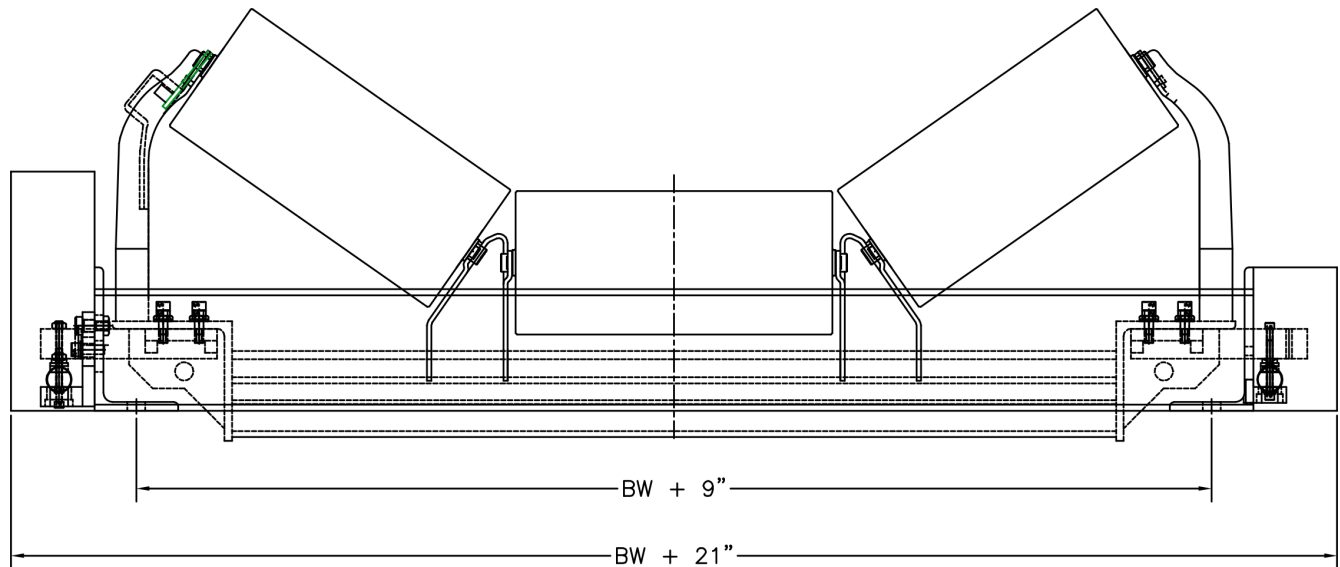

Covered under one or more of the following patents:
4,202,437;4,231,471;4,436,446;4,489,823;4,533,036;4,779,716;4,877,125;
4,989,727;5,149,305;5,222,588;5,222,589;5,219,063;5,350,053;5,725,083
other patents pending



Note: If available, prices vary with options.