

GSS SECONDARY[®] BELT CLEANER

- ✓ Simple Installation
- ✓ Low Maintenance
- ✓ Urethane Blade
- ✓ Fast Delivery
- ✓ Splice Safe



MOUNTING OPTIONS

INDICATES "STANDARD" CONFIGURATION

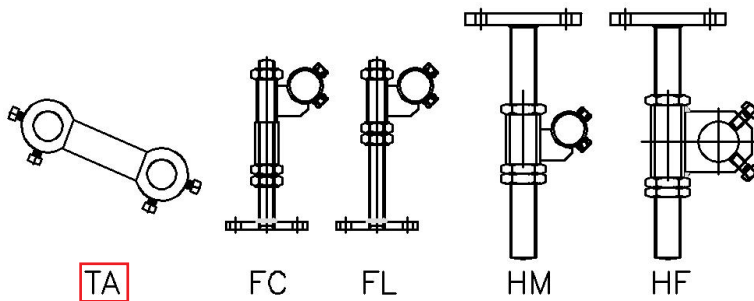

- Patented *Twister Tensioner*[®] maintains constant blade-to-belt pressure and its core is GUARANTEED FOR LIFE!
- Constant re-tensioning not required.
- Steel frame and cantilever arms for heavy-duty applications.
- Eliminates carryback before it damages your belts and idlers.
- Vertical installation is ideal for narrow spaces.



WHO IS ARCH ENVIRONMENTAL?

Manufacturer and worldwide distributor of preferred bulk conveyor components since 1975.



800.553.4567 www.archenv.com

MECHANICAL DIVISION

Belt Cleaners • Belt Alignment • Sealing Systems
Dust Control Systems • Impact/Slider Systems

ELECTRICAL DIVISION

Belt Scales • Metal Detectors • Pull Cord Switches
Belt Protection Devices • Conveyor Control Systems

GSS SECONDARY[®] BELT CLEANER

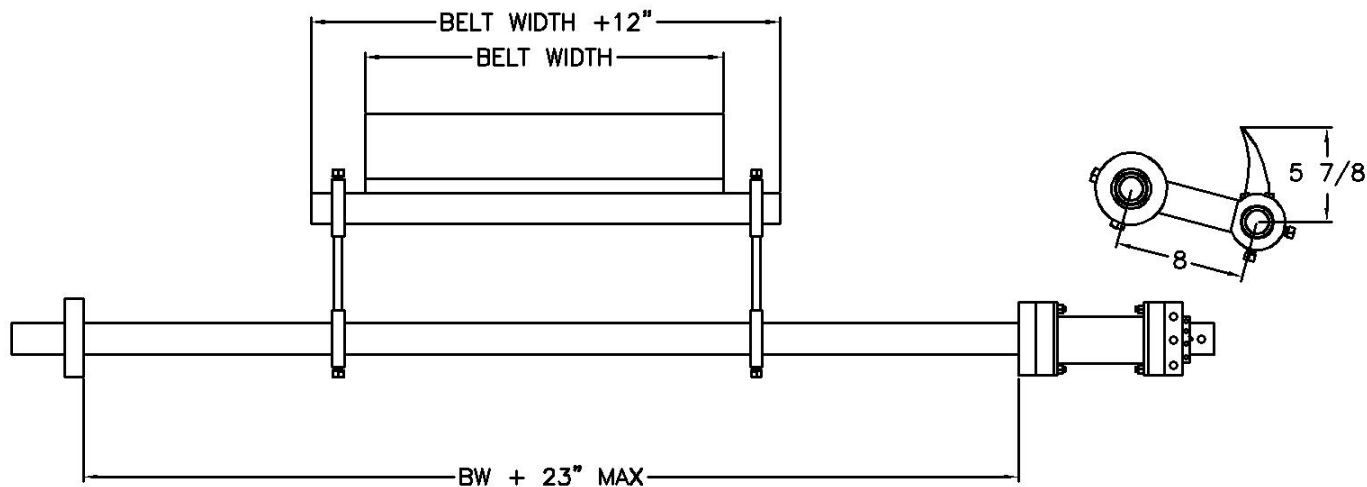
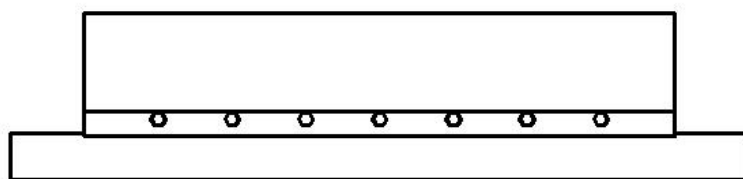

Covered under one or more of the following patents:
4,202,437;4,231,471;4,436,446;4,489,823;4,533,036;4,779,716;4,877,125;
4,989,727;5,149,305;5,222,588;5,222,589;5,219,063;5,350,053;5,725,083
other patents pending



Note: If available, prices vary with options.