



# TALON SKIRTBOARD SEAL

## [INSTALLATION INSTRUCTIONS]

THE TOOLS & RESOURCES REQUIRED ARE:

1. RAZOR KNIFE
2. MEASURING TAPE

**SHUT DOWN AND LOCKOUT CONVEYOR BEFORE PERFORMING ANY MAINTENANCE**

### STEP 1

Establish the location where the seal will be installed and remove existing skirt rubber (if any). Check the length of the area and cut the Talon Seal to length as required. (Cutting may not be required if ordered to length from the factory) A gap of approximately 1 ¼"-1 ½" is required between the chute wall and belt surface.

### STEP 2

Install the rubber under the existing skirt clamp system. Ensure the grooved portion of the seal is against the belt.

### STEP 3

As the skirt clamps are secured in place, ensure the heel of the rubber is pushed down so it flexes and provides a positive seal.

### STEP 4

Test run the conveyor. Inspect the installation for proper sealing and ensure the mounting arrangement will not allow the seal to become dislodged while conveyor is in normal operation.

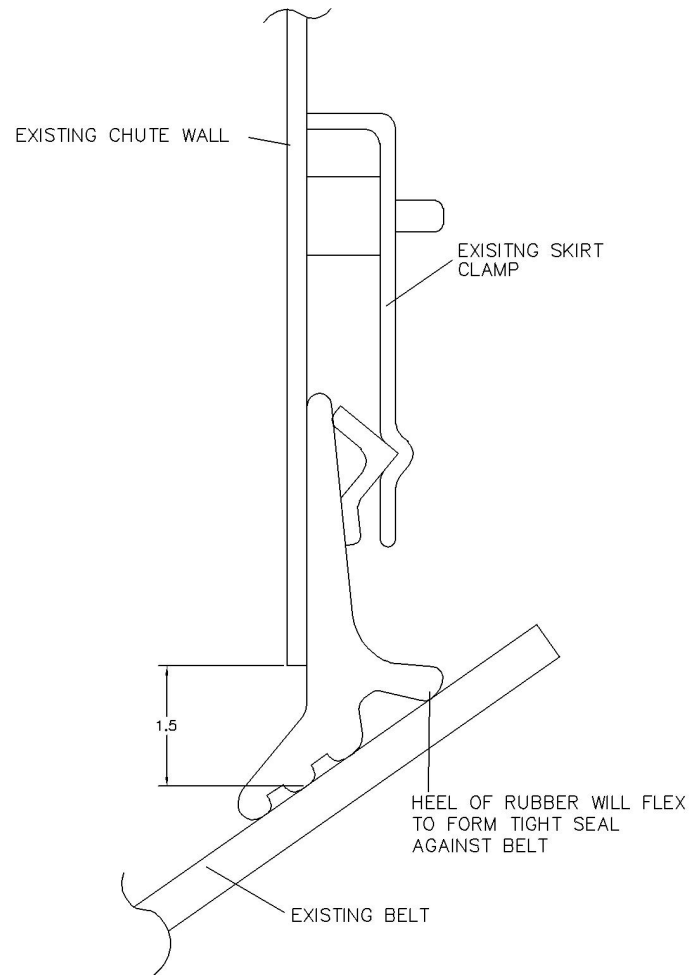

If there are any questions or comments, please contact Arch at 1.800.553.4567.

**THANK YOU FOR USING ARCH PRODUCTS!**