



AT-LAST-A-SEAL SKIRTBOARD SEAL

[INSTALLATION INSTRUCTIONS]

THE TOOLS & RESOURCES REQUIRED ARE:

- | | |
|------------------|----------------------|
| 1. STRAIGHT EDGE | 5. WELDING EQUIPMENT |
| 2. LEVEL | 6. CHALK |
| 3. TAPE MEASURE | 7. ADJUSTABLE WRENCH |
| 4. CUTTING TORCH | |

SHUT DOWN AND LOCKOUT CONVEYOR BEFORE PERFORMING ANY MAINTENANCE

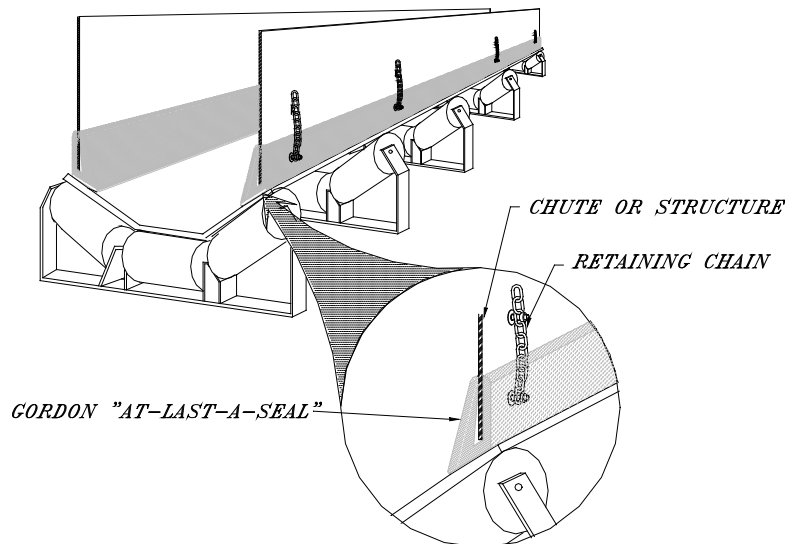

Note: A good quality rubber lubricant applied to the inside of the skirt rubber will make the installation much easier.

STEP 1

NOTE: Arch Environmental Equipment, Inc. recommends installing a deflector piece approximately 1 inch above the skirting in the load zone area. This is necessary to protect the skirting from material falling into the groove and causing premature wear.

The deflector piece can be purchased from Arch Environmental (part # CD-60), or the end user can supply their own. (See Figs 3&4)

Arch part Number and Description: CD-60: 3/8" thick x 60" long hardened steel (weldable)

Determine the clearance between the bottom edge of your chute and the tip of the conveyor belt and determine the chute wall thickness. Maximum wall thickness is 1/2 inch (Fig 1 – Dimension 'A').

For trough angles of 35 and 45 degrees (Fig 1 – Dimension 'B'), use a minimum dimension of 1 3/4 inches to a maximum dimension of 2 inches.

For trough angles of 25 degrees or less, the minimum clearance is 2 1/4 inches and the maximum clearance is 2 1/2 inches (Fig 1 – Dimension 'B').

When installing the "FLAT" At-last-a-seal on a no-troughed belt, the dimension 'B' should be 1 1/2" - 2". Note the Flat At-last-a-seal is a different profile (See Fig 1B)

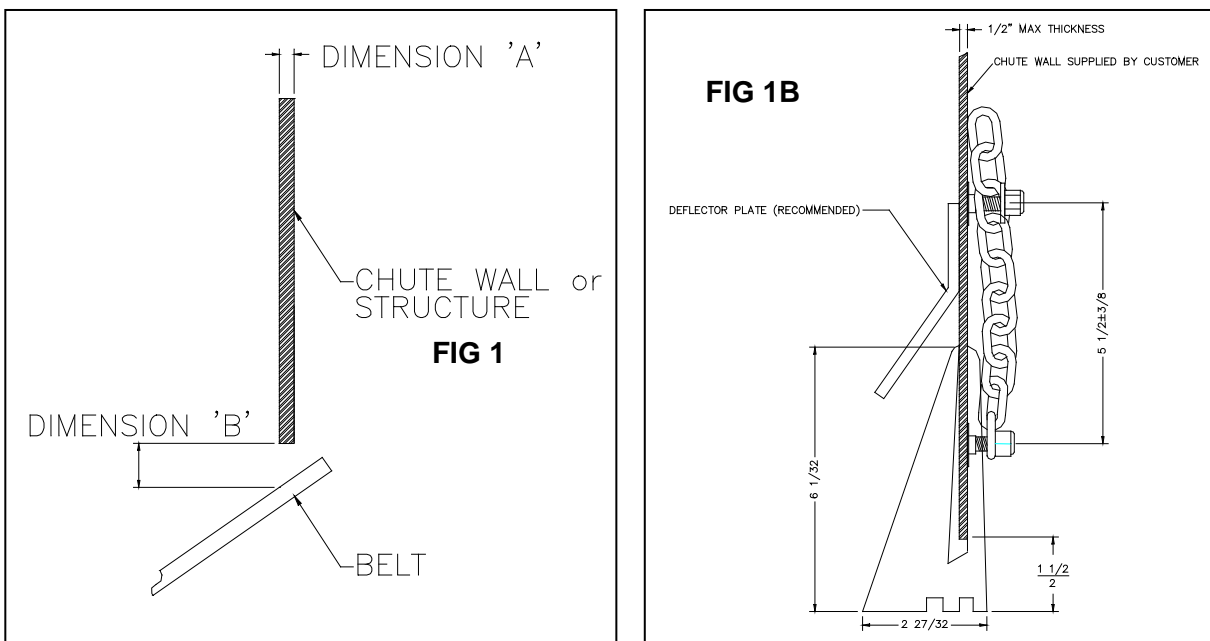

These dimensions will allow the skirt rubber to “float” with the belt and makes it much easier to slide the skirt rubber onto the chute wall. Leave 6 inches of skirt rubber extending past the backside of the chute (Fig 2 – Dimension 'C').

STEP 2

The flat head weld bolt should be inserted in the third link from the end of the chain (Fig 3). The bolt should then be welded to the chute wall directly above the end that is already attached to the skirt rubber. After the bolt is welded in place, remove the chain and reinstall it in the second link from the end. This will give you the proper amount of free chain for the skirt to “float” on.

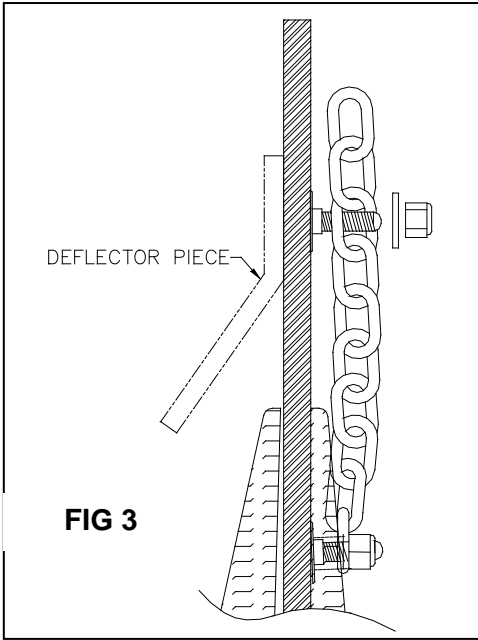
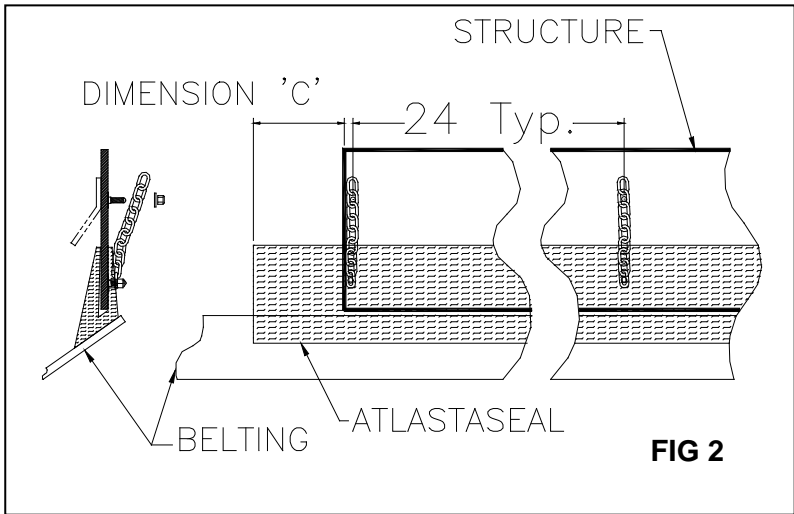

STEP 3

Remove all tools and equipment from the conveyor and do a test run. (Note: The skirt rubber will move forward slightly in the direction of belt travel.) Load the belt with material and check for leakage along the skirt system. The skirt rubber should seal tightly as the material in the chute presses down on it. As the chute empties, the skirt will “relax” slightly away from the belt. Recheck all bolts and nuts to be sure they are installed correctly, and you are finished!

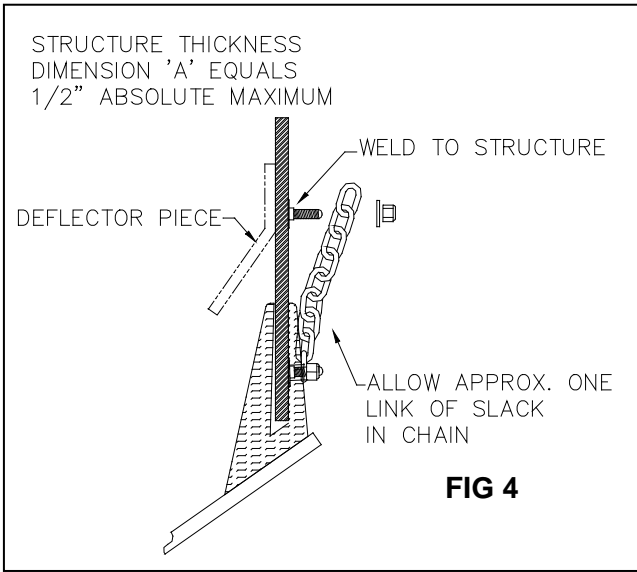

If there are any questions or comments, please contact Arch at 1.800.553.4567.

THANK YOU FOR USING ARCH PRODUCTS!