



MINI SABER BLADE BELT CLEANER

[INSTALLATION INSTRUCTIONS]

THE TOOLS & RESOURCES REQUIRED ARE:

- | | |
|------------------|----------------------|
| 1. STRAIGHT EDGE | 5. WELDING EQUIPMENT |
| 2. LEVEL | 6. CHALK |
| 3. TAPE MEASURE | 7. ADJUSTABLE WRENCH |
| 4. CUTTING TORCH | |

SHUT DOWN AND LOCKOUT CONVEYOR BEFORE PERFORMING ANY MAINTENANCE

STEP 1

Determine the diameter of the head pulley and the thickness of the conveyor belt. Example: head pulley diameter = 24" (609.6mm), belt thickness = 3/4" (19.05mm). Take one half of the head pulley measurement (in this case 12" (304.8mm)) and add the belt thickness. This will give an effective radius of 12 3/4" (325.85mm). To this number add 2 3/8" (60.375mm) (See Fig 1- dimension 'A'). This will give the "Z" dimension. (See Fig 1 – Dimension 'Z'). If your head pulley is smaller than 11" please consult the factor for the correct "A" dimension before installation. The 'A' dimension varies greatly depending upon pulley diameter when below 11."

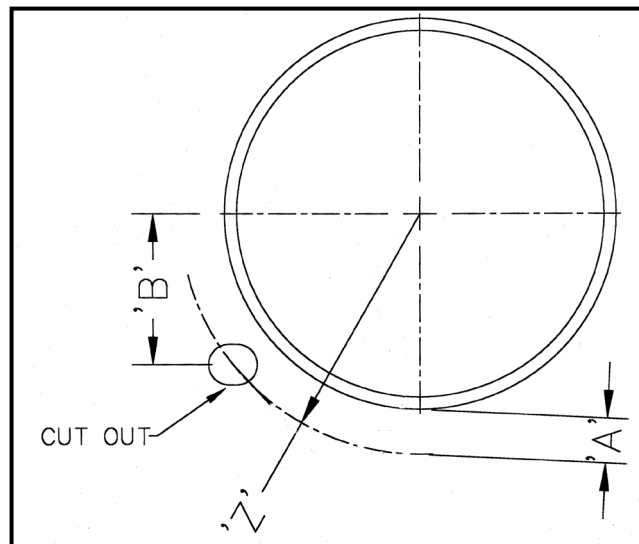

STEP 2

Using the 'Z' dimension, as described in step 1, draw an arc or radius to define the area for cutting the mounting holes on the chute wall.

STEP 3

From the centerline of the head pulley, measure down 6 1/2" (165.1mm). (See Fig 1 - Dimension 'B'). This is the highest point that the cleaner should be mounted. It can be mounted anywhere along the radius that was marked off in step 2. The limiting factor is the restriction of a dribble chute or lack of a dribble chute at the point where the belt leaves the head pulley on the return side.

STEP 4

After you have located the correct position to mount the cleaner, mark two holes approximately 1 7/8" (47.62mm) x 2 7/8" (73.02mm) size. These should now be torched or cut out. You can use the urethane installation rings included with the cleaner to verify the correct location (See Step 6 below).

NOTE: DO NOT USE EXISTING HOLES FROM ANOTHER BRAND OF CLEANER.

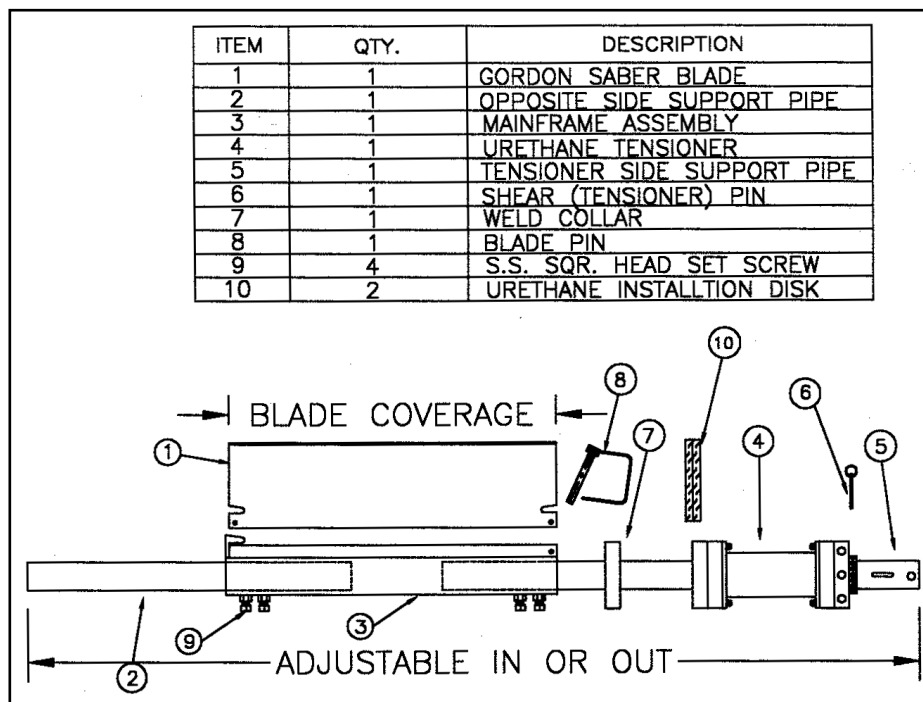

STEP 5

Disassemble the cleaner (Fig 2). This is done by removing the pin (Item 6 – Fig 2) at the end of the tensioner hub. Remove the tensioner (item 4 - FIG. 2) from the tensioner pipe. You will notice that when the tensioner is removed, there is an extra hub (Item 7- Fig 2) behind it. This is the weld collar for the opposite side. You should also find there are two urethane rings within the packaging materials included with the cleaner. The installation rings are used to verify the 'A' and 'Z' dimensions. Loosen the set screws (Item 9 - Fig 2) on the mainframe.

CAUTION! Loosen them only enough to allow both pipes (Items 2&5 - Fig 2) to be removed from the cleaner mainframe (Item 3 - Fig 2).

STEP 6

Put the cleaner (Items 1&3 - Fig 2) inside the chute and slide the support and tensioner pipes (Items 2&5 - Fig 2) through the slots previously cut. Then slide the weld collar (Item 7 - Fig 2) and the tensioner (Item 4 - Fig 2) onto the support and tensioner pipes. Next, level the cleaner in relation to the head pulley. Verify the 'Z' dimension by slipping the installation rings onto the support and tensioner pipe. Then the installation rings should be placed so they bump against the belt face. Tack weld the weld collar and tensioner into place. Set the cleaner blade against the belt and insert the pin (Item 6 - Fig 2) into the tensioner hub. Tighten the sets crews on the mainframe. Now, complete welding on the hubs (3 - 1" (25.4mm) welds on each hub is enough). Pull the pin again to check if the cleaner rotates freely in the hubs; if it doesn't, realign the hubs until it rotates freely.

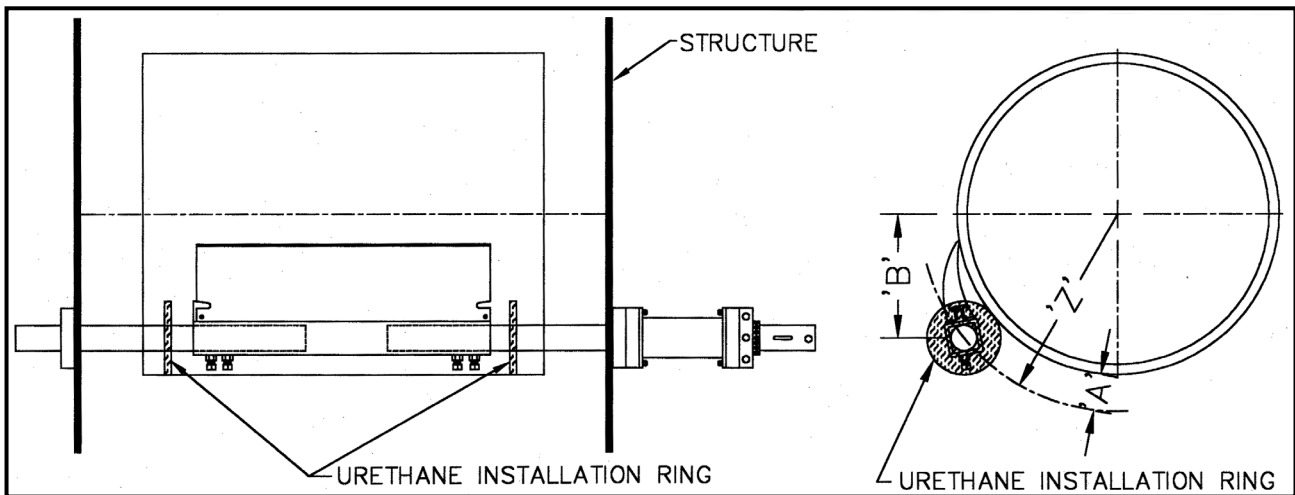

STEP 7

Finally, pull the pin (Item 6 - Fig 2) and rotate the tensioner away from the head pulley, until the next hole shows (See Fig 4) in the tensioner hub. Reinstall the pin.

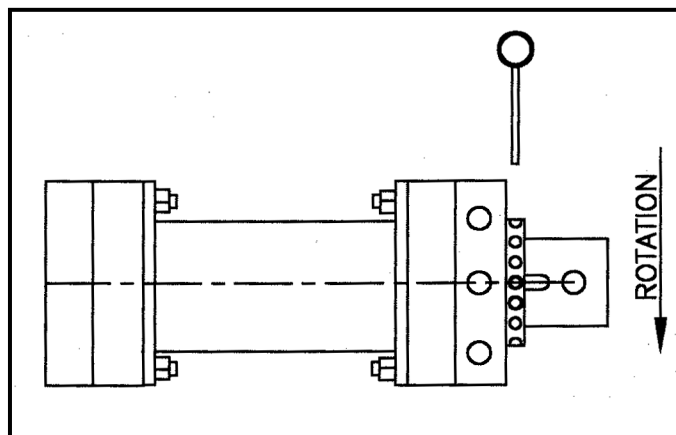

If there are any questions or comments, please contact Arch at 1.800.553.4567.

THANK YOU FOR USING ARCH PRODUCTS!

EXPLODED VIEW

