



SCM/SB PRIMARY BELT CLEANER

[INSTALLATION INSTRUCTIONS]

THE TOOLS & RESOURCES REQUIRED ARE:

- | | |
|------------------|----------------------|
| 1. TAPE MEASURE | 5. ADJUSTABLE WRENCH |
| 2. STRAIGHT EDGE | 6. WELDING EQUIPMENT |
| 3. CUTTING TORCH | 7. CHALK |
| 4. LEVEL | 8. STRING (36"+) |

SHUT DOWN AND LOCKOUT CONVEYOR BEFORE PERFORMING ANY MAINTENANCE

STEP 1

Determine the diameter of the head pulley and the thickness of the conveyor belt. Example: head pulley diameter = 24" (609.6mm), belt thickness = $\frac{3}{4}$ " (19.05mm). Take one half of the head pulley measurement (in this case 12" (304.8mm)) and add the belt thickness. This will give an effective radius of 12 $\frac{3}{4}$ " (323.85mm).

STEP 2

To this number add dimension 'A' (either 2 $\frac{3}{4}$ " (69.85mm) or 3 $\frac{1}{2}$ " (88.9mm)). To determine dimension 'A' (spacing from the face of the belt), you must first determine the head pulley diameter. If the pulley diameter is 22" or smaller, then an 'A' dimension of 3 $\frac{1}{2}$ " (88.9mm) should be used. If the head pulley diameter is larger than 22", use an 'A' dimension of 2 $\frac{3}{4}$ ". This will give you the 'Z' dimension. See Fig 1. To assist you in achieving this spacing, urethane "installation rings" have been included with the cleaner (see figure 3). Use these as directed in step 7.

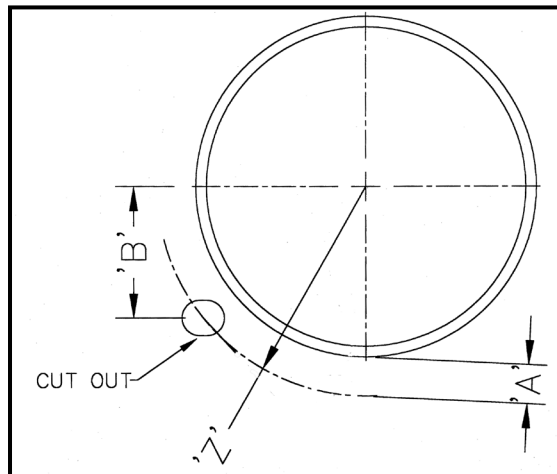

FIG 1

STEP 3

Using the 'Z' dimension as described in Step 2, use the string and chalk to draw an arc (with radius of 'Z') to define the area for cutting the mounting holes on the chute wall.

STEP 4

From the centerline of the head pulley measure down 9 1/2" (241.3mm) (See Fig 1, Dimension 'B'). This is the highest point that the cleaner should be mounted. It can be mounted anywhere along the radius that was marked off in step 3. The limiting factor is the restriction of a dribble chute or lack of a dribble chute at the point where the belt leaves the head pulley on the return side. **Note: DO NOT install the cleaner within the trajectory of the material.**

STEP 5

After you have located the correct position to mount the cleaner on the conveyor structure, mark two slots approximately 2 1/2" (63.5mm) x 3" (76.2mm) in size. These should now be torched or cut out. **Note: DO NOT use existing holes from another brand of cleaner.**

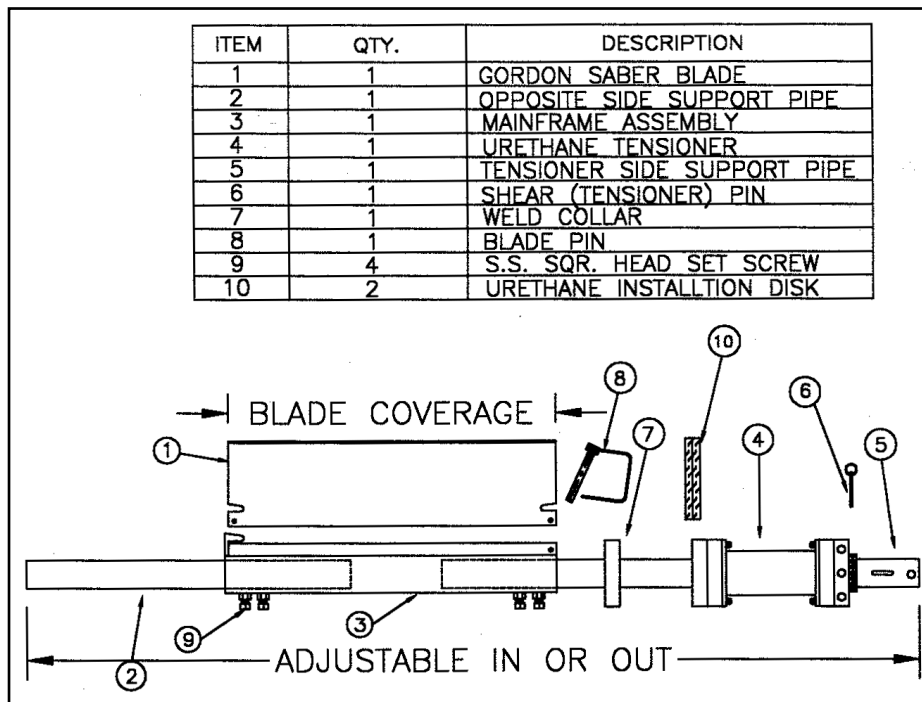

STEP 6

Disassemble the cleaner (Fig 2). This is done by removing the pin (Item 6) at the end of the tensioner hub. Remove the tensioner (Item 4 - Fig 2) from the tensioner pipe. You will notice whenever the tensioner is removed, there is another weld collar (Item 7 - Fig 2). This is the weld collar for the opposite side. There will also be two urethane installation rings used to verify the 'Z' and 'A' dimensions. The two urethane rings (Item 10 - Fig 2) and tensioning instructions will be found packaged to the cleaner. You will also find the tensioner wrench inside the tensioner pipe. Loosen the setscrews (Item 9 - Fig 2) on the mainframe. **Caution! Loosen them only enough to allow both pipes (Items 2 & 5 - Fig 2) to be removed from the cleaner mainframe (Item 3 - Fig 2).** Note: On dual tensioner cleaners there will be no item 7 included. Instead, you will have two of item 4.

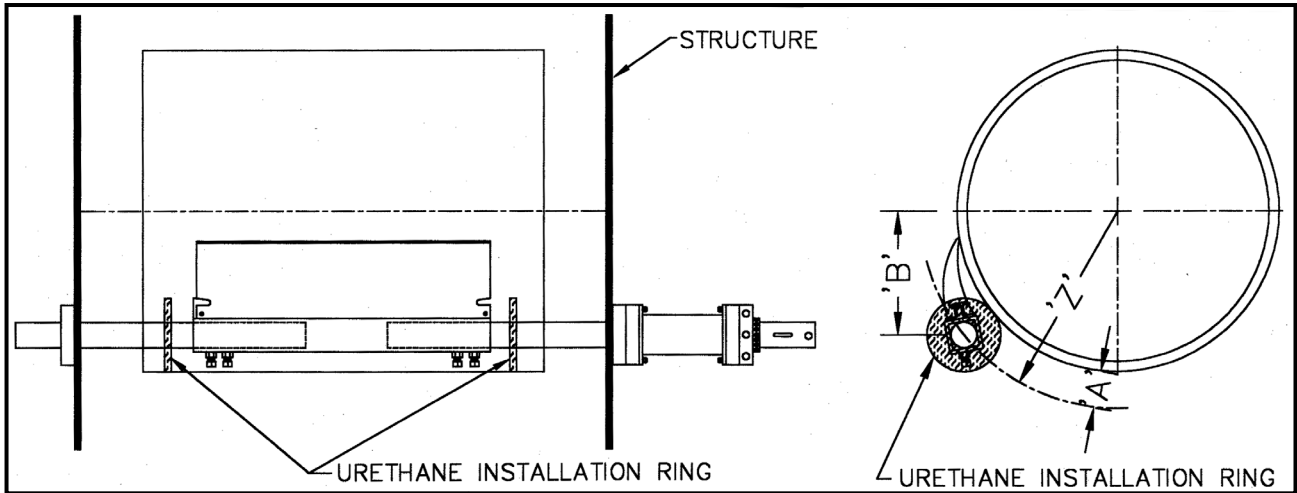

FIG 3

STEP 7

Put the frame and blade assembly (Items 1 & 3 - Fig 2) inside the chute and slide the support and tensioner pipes (Items 2 & 5 - Fig 2) through the 2 1/2" (63.5mm) x 3" (76.2mm) holes previously cut. Then slide the weld collar (Item 7 - Fig 2) and the tensioner (Item 4 - Fig 2) onto the support & tensioner pipes. Next, level the cleaner in relation to the head pulley. Verify the 'Z' dimension by slipping the installation rings (see figure 3) onto the support & tensioner pipe. If the head pulley diameter is larger than 22", remove the outer ring. The installation ring should be placed so that bumps against the belt face. Tack weld the weld collar and tensioner into place. Set the cleaner blade against the belt and insert the pin (Item 6 - Fig 2) into the tensioner hub. Tighten the setscrews on the mainframe and complete welding on the hubs (3-1" (25.1mm) welds on each hub is enough). Pull the pin again to check if the cleaner rotates freely in the hubs; if it doesn't, realign the hubs until it rotates freely. Note: For dual tensioner cleaners, there will not be an item 7, it is replaced by a second item 4.

STEP 8

Finally, pull the pin (Item 6 - Fig 2) and rotate the tensioner away from the head pulley, until the next hole shows (See Fig 4) in the tensioner hub. Reinstall the pin.

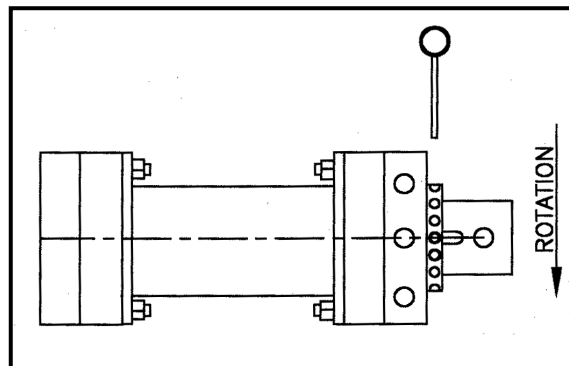

FIG 4

If there are any questions or comments, please contact Arch at 1.800.553.4567.

THANK YOU FOR USING ARCH PRODUCTS!

